

## DS-1682ZJ-P

Extendable Pole for Pendant Mount



### Feature

- Aluminum alloy with surface spray treatment
- Cooperate with the pendant mount (DS-1661ZJ, DS-1662ZJ)

### Dimension

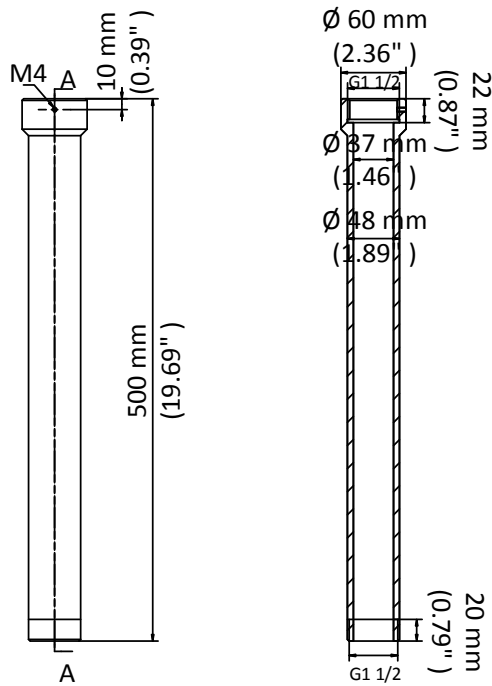

### Available Model

DS-1682ZJ-P

### Parameter

Model	DS-1682ZJ-P
Parameters	Extendable Pole for Pendant Mount
Appearance	Platinum Gray
Material	Aluminum Alloy
Dimension	Ø 60 mm × 500 mm (Ø 2.36" × 19.69")
Weight	1050 g (2.31 lb.)

### Note

- The mount should be installed on the flat surface.
- The waterproofing measures are necessary for the outdoor application.
- The wall must be capable of supporting at least 3 times as much as the total weight of the camera and the mount.
- The mount's maximum load capacity is 10 kg (22 lb.).