

# Premier 360DT

## Ceiling Mount Dual Technology Detector



### Cover every angle

The perfect detection solution for partitioned areas, commercial premises and residential homes, the Premier 360 DT provides all-round security.

Featuring a combination of omni-directional quad PIR sensing and state-of-the-art K-band microwave detection, the Premier 360 DT provides unparalleled catch performance even in the most challenging of environments.

- 3.6m maximum mounting height
- 9.3m maximum diameter coverage pattern
- Conforms to EN50131-2-4 Grade 2 requirements\*

\*For details of specific territory listings, please contact your Texecom sales representative

**For further information contact sales: 01706 220460**

**Texecom**

# Premier 360 DT - Ceiling Mount Dual Technology Detector

The Premier 360 DT from Texecom is a ceiling mount intruder detector that features both omni-directional quad element PIR and K-band microwave sensing. This gives the detector maximum catch performance and false alarm immunity, even in challenging environments such as partitioned areas, commercial premises and residential housing.

The Premier 360 DT has a maximum 9.3m diameter detection pattern, which results in over 65m<sup>2</sup> of omni-directional coverage under each detector. The product is suitable for mounting up to 3.6m above the ground, and complies with EN50131-2-4 Grade 2 requirements.

Ceiling mount detectors are of particular benefit when protecting areas with ground-based obstructions such as cubicle partitions, shopping aisles and large furniture, or when traditional mounting sites are impractical.

## Physical Specifications

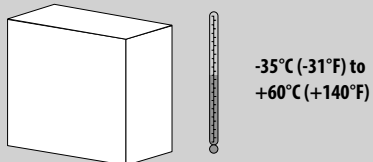
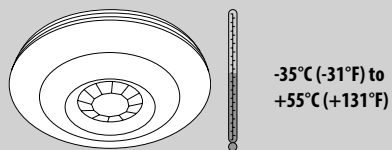
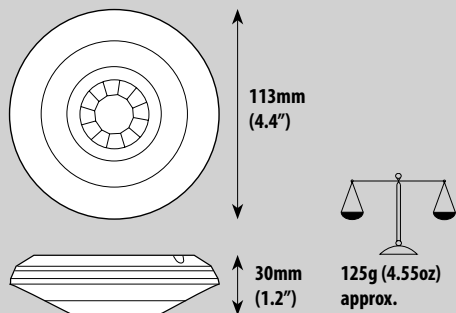

## Premier 360 DT



## Functions

- 9.3m coverage pattern
- 3.6m maximum mounting height
- Omni-directional quad pyro sensing
- K-band microwave detection
- Digital microprocessor technology
- Conforms to EN50131-2-4 requirements

## Standards

Detector Standard:	EN 50131-2-4 Grade 2 Class II
System Standard:	PD 6662/BS EN 50131-1 Grade 2 system, Environmental Class II
Frequency:	24Ghz

## European Standards

CE Directive: 2004/108/EC (CE directive): Hereby, Texecom Ltd declares that this device is in compliance with the essential requirements and other relevant provisions of Directive 2004/108/EC.

R&TTE Directive: 1999/5/EC (R&TTE Directive): Hereby, Texecom Ltd declares that this device is in compliance with the essential requirements and other relevant provisions of Directive 1999/5/EC.

Texecom products are protected by UK and International patents, trademarks and registered design rights. Premier is a trademark of Texecom Ltd.

© 2011 Texecom Limited. LIT-0155-2 Discover more at [www.texecom.com](http://www.texecom.com)



Certificate Number: FM 35285

british security industry association

**CE 0682**